

# Autonomous Snowplow Design

Samantha Craig, Adam Naab-Levy, Kuangmin Li, Ryan Kollar, Pengfei Duan, Wouter Pelgrum, Frank van Graas, Maarten Uijt de Haag  
*Ohio University*

## BIOGRAPHIES

Samantha Craig is pursuing a Master's Degree in Electrical Engineering at Ohio University, where she also obtained her Bachelor's Degree. She has a wide range of academic interests including avionics, GPS, timing, and engineering management. Her current research focuses on the characterization of Rubidium oscillator performance due to environmental variations.

Adam Naab-Levy is a graduate student at Ohio University pursuing a M.S. degree in Electrical Engineering. His current research endeavors focus on terrestrial L-Band radionavigation performance in support of the APNT program. In addition, he is interested in robotics, sensor fusion, and parallel programming.

Kuangmin Li is pursuing a Ph.D. degree in Electrical Engineering at Ohio University. His research focuses on navigation-related topics, such as enhanced distance measuring equipment, accurate timing, multipath mitigation techniques and software defined radio. Kuangmin received his bachelor's and master's degree in Physics from University of Science and Technology of China and Ohio University, respectively.

Ryan Kollar is studying Electrical Engineering at Ohio University. He is the recipient of the McFarland Electrical Engineering Scholarship and his academic interests include navigation, logic design, and GPS. Outside of the classroom he is a member of Tau Beta Pi and IEEE chapters. After completing his undergraduate program, he plans to continue his education with a graduate program in avionics at Ohio University.

Pengfei "Phil" Duan is pursuing a Ph.D. degree in Avionics Engineering Center, Department of Electrical Engineering and Computer Science at Ohio University, where he also received his M.S.E.E. degree. His research interests include conflict detection & resolution, system integrity, integrated navigation system, cockpit alerting system, and ADS-B.

Wouter Pelgrum is an Assistant Professor of Electrical Engineering at Ohio University where he researches and teaches electronic navigation-related topics such as GNSS, DME, Loran, Time and Frequency transfer. Before he joined Ohio University in 2009, Wouter worked in private industry where he contributed to the

development of an integrated GPS-eLoran receiver and antenna. From 2006 until 2008 he operated his own company, specializing in navigation-related research and consulting.

Frank van Graas is a Fritz J. and Dolores H. Russ Professor of Electrical Engineering and Principal Investigator with the Avionics Engineering Center at Ohio University. He is an Ohio University Presidential Research Scholar and a Past President of The Institute of Navigation (ION). He received the ION Johannes Kepler and Thurlow awards, and is a Fellow of the ION. He served as the ION Executive Branch Science and Technology Policy Fellow in the Space Communication and Navigation Office at NASA Headquarters during the 2008-2009 academic year. At Ohio, his research interests include all facets of GPS, inertial navigation, LADAR/EO/IR, surveillance and flight test.

Maarten Uijt de Haag is an Edmund K. Cheng Professor of Electrical Engineering at Ohio University and a Principal Investigator with the Ohio University Avionics Engineering Center. He earned his Ph.D. from Ohio University and holds a B.S.E.E. and M.S.E.E. from Delft University of Technology, located in the Netherlands. He is a member of the ION, a Senior member of the IEEE and an Associate Fellow of the AIAA. Dr. Uijt de Haag was the recipient of the Institute of Navigation Thurlow Award in 2007.

## ABSTRACT

A monocular autonomously-controlled snowplow (M.A.C.S.) was designed for participation in the Third Annual Autonomous Snowplow Competition. The name M.A.C.S. stems from the vehicle's most prominent and key feature: a single rotating laser. This laser is the main component of the vehicle's guidance system. The robot's drivetrain consists of four electric motors with shaft mounted encoders for velocity feedback. These motors provide a total of 5 hp to propel the 526-lb snowplow measuring 1.27 m long, 0.96 m wide and 0.97 m tall. Given M.A.C.S.'s size and weight, safety is critical. WiFi communications are utilized for remote control operations and relay of status information, as well as a separate radio-control for emergency power shut-off. All of the above features and components are integrated using a Matlab<sup>®</sup>-based development environment for rapid prototyping and algorithm design, while low-level

commands are implemented using C++ for speed and latency. During the competition, M.A.C.S. autonomously, and completely, cleared snow from two competition fields: a 1-m wide by 10-m long “I”-shaped field, and a double “I”-shaped field with the same length and a width of 2 m, earning team Ohio University the maximum score for each competition run. Team M.A.C.S. also earned an additional 2.13 bonus points and 3.48 bonus points, respectively, for speed of course completion. In addition, Ohio University received a score of 14.36 out of a possible 15 points and a score of 8.41 out of a possible 10 points for the competition’s presentation and technical paper components, respectfully. Team M.A.C.S. earned a total of 103.11 points out of a possible 107.5, including bonus points, winning the competition.

**INTRODUCTION**

The Third Annual Autonomous Snowplow Competition (ASC) (January 24<sup>th</sup> through January 27<sup>th</sup>, 2013 in St. Paul, MN) challenges teams in the areas of guidance, navigation, and control (GNC) to develop a robot that autonomously removes snow from two separate fields, as stated in the Competition’s rulebook [1].

To accomplish this task, Ohio University assembled a team consisting of one undergraduate and four graduate students in Electrical Engineering, whose activities were overseen by three faculty members. The snowplow design used Ohio University’s 2012 competition vehicle as the starting point as shown in Figure 1. The software and mechanical design were modified to improve vehicle performance and to address the challenges of the Third Annual ASC. Several of these changes are summarized below, with more detail provided in [1].



Figure 1. Ohio University’s Entry in the Second Annual ASC

- 1) A double “I”-shaped field with a length of 10-m and a width of 2-m to replace the previous “U”-shaped field, as described in both [2] and [3]
- 2) The addition of a second simulated post placed randomly within the Maneuvering & Plowed Snow Zones
- 3) Simulated posts present during both competition runs
- 4) A vehicle parking zone

- 5) Boundary alterations decreasing the size of the Maneuvering & Plowed Snow Zones

The above competition challenges combined with operational experience from the previous two competitions resulted in the following software modifications:

- 1) A robust initialization algorithm to distinguish the simulated posts from navigation aids
- 2) A controlled-radius turning procedure to optimize path planning and to more cautiously utilize the Maneuvering & Plowed Snow Zones
- 3) An unstuck maneuver in the event that snow build-up prohibits movement
- 4) A blade un-flip maneuver
- 5) A “boundary checking” algorithm to determine whether dynamic re-planning procedures will cause boundary infractions

M.A.C.S. also underwent several mechanical alterations, including placing the two sets of batteries in parallel for increasing power capacity, and the installation of limit sensors to detect the position of the plow blade; either flipped or un-flipped. For a complete description of the design of M.A.C.S., portions of the technical papers from both the Second Annual ASC and the First Annual ASC have been summarized in this report. For full versions of these papers, the reader is referred to [2] and [3], respectively.

**TOP LEVEL REQUIREMENTS**

The snowplow competition requirements are detailed in the Third Annual ASC Rulebook [1]. Table 1 provides a summary of the snowplow Vehicle Design Constraints (VDC), and Table 2 shows the derived performance requirements. The numerical values of the performance requirements were inherited from the vehicle design for the 2012 competition. Detailed requirements on different levels with full traceability are provided in Appendix A.

Table 1. Snowplow Vehicle Design Constraints

ID	Vehicle Design Constraints (VDC) [1]
1	The snowplow shall be autonomous and unmanned and shall not be remotely controlled during the competition.
2	The snowplow shall observe a speed limit of 2 m/s.
3	The system shall be equipped with both a physical power-off switch and a wireless remote power-off switch. The snowplow shall cease operation and come to a complete stop within 3 m upon power-off. The snowplow shall be equipped with an electrical ground.
4	The snowplow and any of its attachments shall not exceed 2 m in any dimension.
5	The snowplow tires shall not be augmented with rivets, spikes, or chains, and plowing action shall be accomplished through direct contact with the ground surface.

6	The snowplow shall be self-powered and contain no power source external to the vehicle. Power shall either be combustible fuel, batteries, or both.
7	Possible points per run will be calculated using the equation defined in §3.4.3 of [1]
8	Two fixed posts approximately 1.5 m high by 0.2 m wide will be placed within the Maneuvering & Plowed Snow Zones during each of the snowfield runs.
9	Competition specific design requirements: 1) The snowplow will complete each course in under 20 minutes (including set up time); 2) The snowplow must stay within the buffer zones; 3) The snowplow shall operate in any weather condition (except for severe weather); 4) Navigation aiding sources must be self-powered; 5) The snowplow must operate with snow depths of approx. 5-10 cm; 6) The snowplow must completely clear all the snow from the snowfield paths; 7) The snowplow must start and finish within the Vehicle Starting Zone (Garage) on the snowfield.

Table 2. Snowplow Vehicle Performance Requirements

ID	Requirement	Value
1	Position accuracy	5 cm (rms)
2	Heading accuracy	10 mrad (rms)
3	Maximum speed	2 m/s
4	Safety stopping distance	< 3 m
5	Safety response time	< 1 s
6	Blade angle	26 deg
7	Weight	> 500 lbs
8	Turn radius	< 1 m
9	Environmental Conditions	-30° to 60° F Snow < 2 in/hr (values from [4])
10	Dimensions	< 2 m

## CONCEPT/PLOWING STRATEGY

Ohio University’s plowing strategy utilizes a 1.07-m wide plow at an angle of 26° to give an effective plowing width of 96 cm. This plowing width allows for a 23-cm overlap on either side of the intended 50-cm path based on the position solution accuracy and the guidance and control accuracy observed during testing.

Multiple plowing scenarios were tested to most effectively clear the double “I”-shaped path. The procedure that proved to be the most robust, given extensive testing with snow loading and dynamics, is outlined below and is illustrated in Figure 2.

- 1) An outer loop (green in Figure 2)
- 2) An inner loop (blue in Figure 2)
- 3) Another outer loop to clear any residual snow from (2) (green in Figure 2)
- 4) A final “clean-up” pass down the center of the field to remove any remaining snow, particularly due to turning procedures (red in Figure 2)

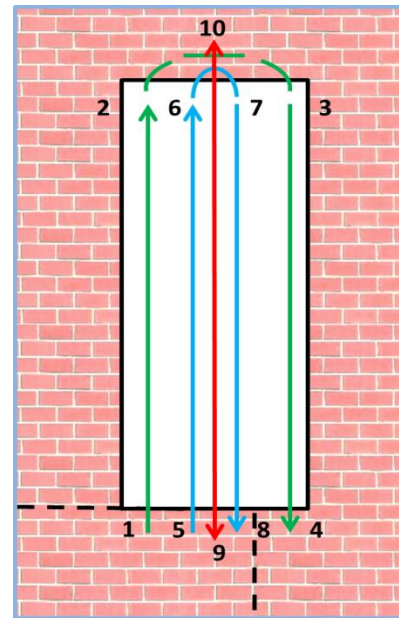

Figure 2. Ohio University’s Plowing Strategy for the Double “I”-shaped Field

For the outer loops, M.A.C.S. first proceeds from plow position 1 to 2, at a speed of 1 m/s, after which it makes a 90° turn, followed by a straight segment, before making another 90° turn to arrive at position 3. To complete the outer loop, the robot will proceed straight to position 4, again at a speed of 1 m/s. The inner loop consists of moving forward from position 5 to 6, making a 180° turn to end up at position 7. M.A.C.S. then proceeds forward to position 8. After a 180° turn, M.A.C.S. will make a final pass down the center of the snowfield from position 9 to 10 in order to clear any remaining snow before backing up to return to position 9 and enter the vehicle “garage”, as specified in [1]. The final “clean-up” pass is executed at a speed of 1.5 m/s, as there is minimal snow remaining, reducing the likelihood of snow build-up or traction issues.

The plowing strategy for the “I”-shaped snowfield is a subset of the double “I”-shaped strategy; only the inner loop is used, starting from position 5 in Figure 2.

Acceleration of the vehicle is controlled to minimize wheel slip during acceleration. A typical maximum acceleration of 2 m/s<sup>2</sup> was found to be adequate. In the unlikely case where the snowplow does not move due to wheel slip or excessive snow build-up, the guidance system commands the snowplow to back up and try again until forward motion has been re-established. In the event that the plow blade flips forward due to excessive snow loading, the limit switches mounted on the plow will trigger a back-up response from the robot, allowing for reduced tension on the blade mount causing it to return to its intended position. Both of these procedures are described in greater detail in following sections.

## SNOWPLOW VEHICLE DESIGN

A high-level block diagram of M.A.C.S. is provided in Figure 3. At the center of the block diagram is an AMD 64-bit, 2.4 GHz Quad-Core processor with a 64 GB Solid State Drive (SSD) to enable low-temperature operations. The processor handles all sensor interfacing and data recording.

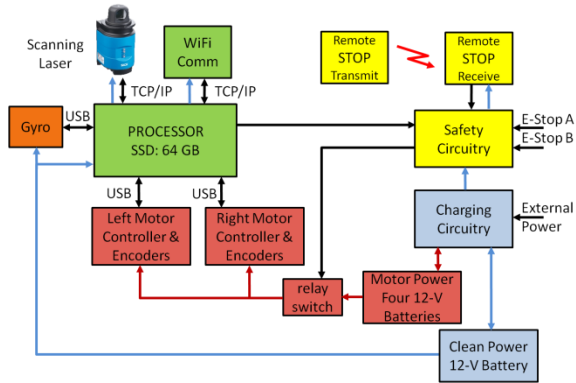

Figure 3. M.A.C.S. High-Level Block Diagram

Power is divided into clean power and motor power. The clean power uses a 12 V, 31.6 Ah gel battery, while the motor power is supplied via four 12 V batteries, connected in a series/parallel configuration, to provide 24 V with 63.2 Ah. This design increases peak power output and extends the runtime of plowing operations by equally distributing the electrical load across all four batteries. The battery status and charging system, detailed in the Second Annual ASC Paper, was utilized again for the 2013 competition [2].

The snowplow blade, shown in Figure 4, was modified to include two industrial limit switches. The redundantly wired switches allow M.A.C.S. to detect a "flipped" blade failure mode and initiate recovery actions. The switches are electrically connected to the robot via a mil-spec connector. This connector, along with a commercial tractor blade attachment, facilitates easy removal of the blade so that the robot can fit through standard doorways.

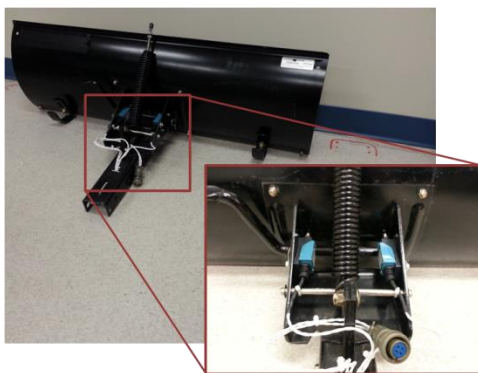

Figure 4. M.A.C.S. blade with limit switches

The entire top-half of the robot is sealed with high density foam tape to shield sensitive electronics and batteries from adverse environmental conditions such as water, snow and low temperatures. The lower center portion of the robot is designed to hold additional weight to increase tire traction.

## NAVIGATION SYSTEM DESIGN

Following a trade-off study that included GNSS, camera, and laser solutions, the laser positioning method was selected as most effective and robust to meet the system requirements and satisfy the navigation objectives of M.A.C.S., see Table 2. The SICK LD-OEM1000 scanning laser was selected, which makes range measurements with the angular resolution of  $0.25^\circ$  in the  $360^\circ$  field of view. To obtain the position solution of M.A.C.S., the laser bearings and ranges from several pre-determined beacons are used. The measurement geometry is illustrated in Figure 5.

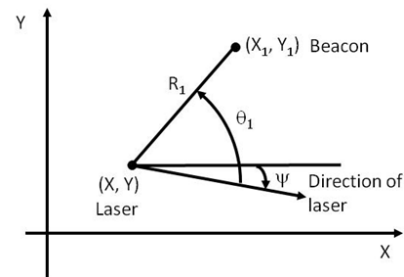

Figure 5. Scanning Laser Measurement Geometry

With the known beacon position  $(X_1, Y_1)$ , the laser range measurement  $R_1$  and angle measurement  $\theta_1$ , and the unknown laser position  $(X, Y)$  and heading angle  $\psi$ , the measurement equation can be expressed as

$$\begin{pmatrix} X_1 \\ Y_1 \end{pmatrix} = \begin{pmatrix} 1 & 0 & -R_1 \sin(\theta_1) & R_1 \cos(\theta_1) \\ 0 & 1 & R_1 \cos(\theta_1) & R_1 \sin(\theta_1) \end{pmatrix} \begin{pmatrix} X \\ Y \\ \sin(\psi) \\ \cos(\psi) \end{pmatrix} \quad (1)$$

or  $z = Hx$ .

The laser position and heading angle can then be calculated with a least squares solution:

$$x = (H^T H)^{-1} H^T z \quad (2)$$

A minimum of 2 beacons are required to solve for the 3 unknowns. Additional beacons can be used for fault detection, improved geometry, reduced position noise and will also help in the initialization of the solution.

### Position Integrity

To guarantee position integrity a Fault Detection and Exclusion (FDE) algorithm has been implemented. This algorithm analyzes the beacon residuals, which are calculated by comparing the beacon's mapped positions with their measured positions, assuming the robot's estimated position and orientation. Any residuals exceeding 15 cm trigger an exclusion process: all possible beacon subsets are then analyzed for performance compliance, with an exclusion of up to 3 beacons if needed. A minimal set of 3 valid beacons is required for assured positioning performance.

### Robust Initialization

At the start of each of the competition runs, the robot performs a 15-s initialization procedure for calibration of the heading gyroscope as well as for the creation of a map of the beacons in the local navigation frame. To mitigate the effect of missing laser returns due to snowflakes, the laser scans are first averaged during the initialization to identify only the stationary objects. The averaged scan is then used to initialize the field and obtain the initial position and orientation of M.A.C.S.

One new challenge of the competition is to accommodate two simulated posts in both the "I" and double "I" snowfields [1]. Given that the navigation beacons are placed at known locations and that any combination of two beacons may be blocked by the posts, correlation is used to initialize the solution. Figure 6 illustrates the correlation process using a dataset from an actual double "I" field test. The beacons measured in the local laser scan (Figure 6 - top left) are translated and rotated for all possible initial positions and orientations, and correlated with the known beacon locations and orientation. The search space is from -1.5 m to +1.5 m in both axes of the position search space with an increment of 0.2 m, and from -20 deg to +20 deg in heading with a search increment of 2 deg.

Next, the total residual of all beacons is calculated for every possible combination of 2D position and heading. Minimization of the residual in the search space indicates the best match of the measured beacons to the known map. Finally, the field layout and the first estimate of position solution is determined (Figure 6 - top right). The maximum allowed residual is set to 56 cm, i.e. any beacon with a range residual exceeding 56 cm will be dropped from the solution. The average residual of all beacons as a function of 2D position and heading (correlation functions) is shown in Figure 6 in the middle and lower plots, respectively. A red plus sign (+) in the correlation function plots shows where the truth is. After the initial 2D position and heading are determined from the grid search, a least-squares position is calculated with

a FDE beacon residual threshold of 42 cm. This estimate is then used to re-map the measured beacons to the competition coordinate frame that will be used for positioning throughout the competition run.

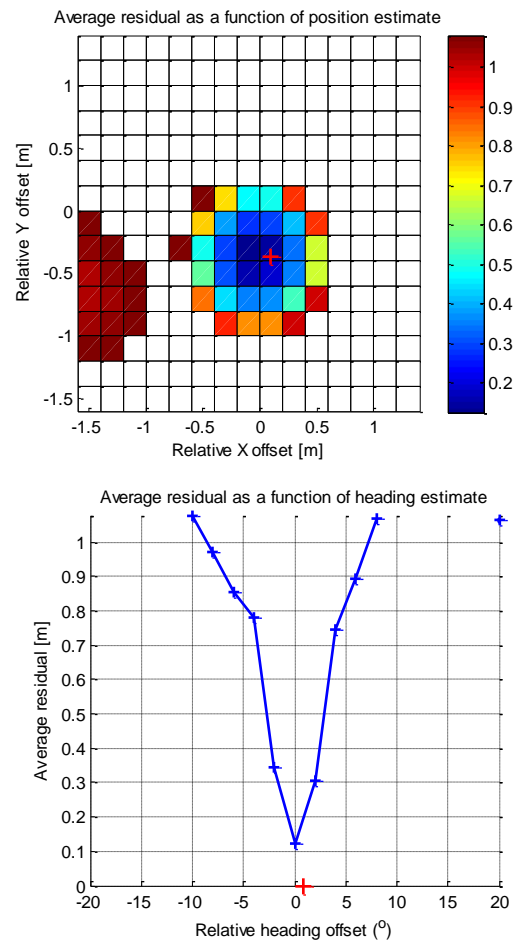
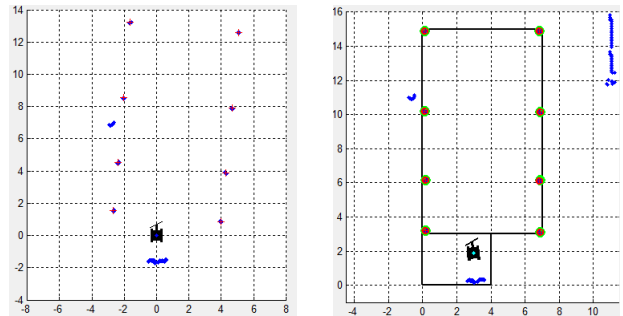

Figure 6. Robust initialization using correlation:  
Top left: Laser scan in M.A.C.S.' local frame  
Top right: Field layout determined by correlation  
Middle: 2D position search correlation function (Red plus sign indicates the truth)  
Lower: Heading search correlation function (Red plus sign indicates the truth)

## BEACON DESIGN AND PLACEMENT

The beacon system used to define the snow field was designed for ease of set up and to provide navigation redundancy. The laser beacons themselves were designed to be clearly visible by the scanning laser and to provide a unique signature. The beacons were constructed using white (highly reflective) polyvinyl chloride (PVC) pipes with a diameter of 4 inches. More detail on beacon construction and design can be found in [2]. The placement of the beacons is primarily driven by the requirement to know the location of the snow field with cm-level accuracy. All beacons are precisely placed using a custom-made ruler. Initialization of the navigation software requires 15 s during which time the gyro drift rate is also estimated while the snowplow is stationary. The beacon positions were selected such that the scan pattern is unique with good navigation geometry throughout the competition field. Figure 7 shows the location of the beacons for both the “I” and double “I”-shaped snow fields, where black circles indicate the beacon locations.

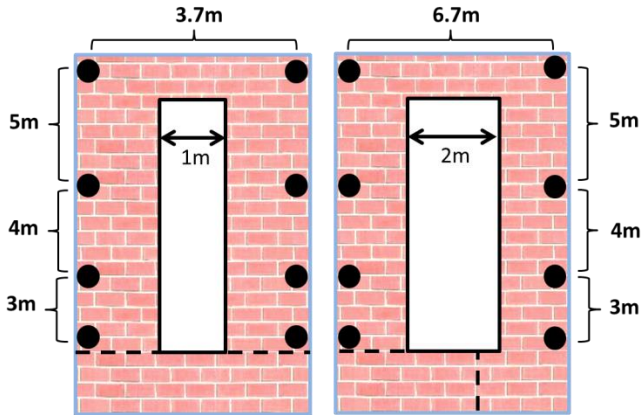

Figure 7. Beacon Placement for “I” (left) and double “I” (right) Snow Fields

## GUIDANCE SYSTEM DESIGN

M.A.C.S. uses several commands which are generated in a script to clear snow from the field. The snowfield coordinates are used to generate command set actions that are executed successively as a function of the snowplow position. The M.A.C.S. command set includes the following commands:

- 1) Initialize
- 2) Idle
- 3) Stop immediately
- 4) Track heading at a set speed (positive or negative), a set acceleration, and a set control gain
- 5) Turn using a commanded final heading at a set speed (for zero speed, the robot will have a zero turn radius)
- 6) Slow stop at a set deceleration and a set control gain
- 7) Back up and retry the original command if vehicle is stuck

- 8) Back up and re-position the plow if blade-flip is detected
- 9) Reduce speed if wheel slip is detected

The command stack is pre-calculated for both the “I” and double “I” fields. The stack is modified when the vehicle detects that it is stuck. In this case, an “unstuck” procedure is added to the command stack, which consists of the following command sequence: stop, move backward (if previous direction was forward) or forward (if previous direction was backward) by a small distance, stop again, and reverse course to continue according to the original stack command.

For the Third Annual ASC, two simulated posts will be placed within the Maneuvering and Plowed Snow Zones for both the “I” and double “I” fields. Stack commands are modified if the simulated posts are determined to interfere with the path of the snowplow. Depending on the location of the obstacles, the snowplow will either 1) increase/decrease the turn radius, 2) add a small path deviation around the obstacle, or 3) back-up earlier to avoid the obstacles with a 0.1 m separation distance. The simulated post avoidance strategy also takes into account the impact on the snow removal score. If it is determined that the post avoidance maneuver will negatively impact the score, the snowplow will not modify the command stack and instead attempt a post position/attitude adjustment to enable completion of the planned path.

## CONTROL SYSTEM DESIGN

The control system for M.A.C.S. uses three control loops:

- 1) Constant rotational velocity control loop using two RoboteQ HDC2450 motor controllers with encoder feedback from all motors. The controllers are updated at 1000 Hz with a 100-Hz Proportional-Integral-Derivative (PID) controller.
- 2) Heading control loop using an XSENS MTi gyro (0.1°/minute drift after calibration) at a 50-Hz update rate with latency below 10 ms. The bandwidth of this loop is approximately 10 Hz.
- 3) Navigation control loop using a SICK LD-OEM1000 scanning laser with passive beacons at an update rate of 5 Hz with latency below 110 ms to adjust for path deviations.

To better optimize for potential plowing strategies, control models for skid-steering mobile robots (SSMRs), like M.A.C.S., were investigated. The work of Kozłowski and Pazderski was the primary reference used to gain a better understanding of a SSMR. The equation shown below represents the kinematic model for a SSMR [5]:

$$\begin{bmatrix} \dot{X} \\ \dot{Y} \\ \dot{\theta} \end{bmatrix} = \begin{bmatrix} \sin \theta & 0 \\ \cos \theta & 0 \\ 0 & 1 \end{bmatrix} \begin{bmatrix} v_x \\ \omega \end{bmatrix} + \begin{bmatrix} -\sin \theta \\ \cos \theta \\ 0 \end{bmatrix} v_y \quad (3)$$

Equation 3 represents a simple two-wheeled robot model perturbed by skidding which is directly associated with the lateral velocity component  $v_y$ .

$$v_y + x_{ICR} \dot{\theta} = 0 \quad (4)$$

The relationship between  $v_y$  and the x-coordinate of the instantaneous center of rotation (ICR) is a non-holonomic velocity constraint which is non-integratable. To simplify the model,  $x_{ICR}$  is set to zero (center of the robot) so that  $v_y$  is forced to zero. This simplification is valid as long as the lateral skidding is not a dominant factor; the case when turn-rate ( $\omega$ ) is kept low. Once this simplification is made, Equation 5 can be used to solve for the robot's effective wheelbase (2c) and wheel radius (r).

$$\begin{bmatrix} v_x \\ \omega \end{bmatrix} = r \begin{bmatrix} \frac{\omega_L + \omega_R}{2} \\ \frac{-\omega_L + \omega_R}{2c} \end{bmatrix} \quad (5)$$

After wheel radius and wheelbase have been determined experimentally, Equation 5 can be used to calculate forward velocity ( $v_x$ ) and turn-rate from the left and right wheel speeds,  $\omega_L$  and  $\omega_R$  respectively. Turn radius can then be calculated from the expression:

$$\text{Turn Radius} \cong \frac{v_x}{\omega} \quad (6)$$

Figure 8 summarizes the results and illustrates the validity of the approximation for wheel radius = 31.2 cm and wheelbase = 1.0 m.

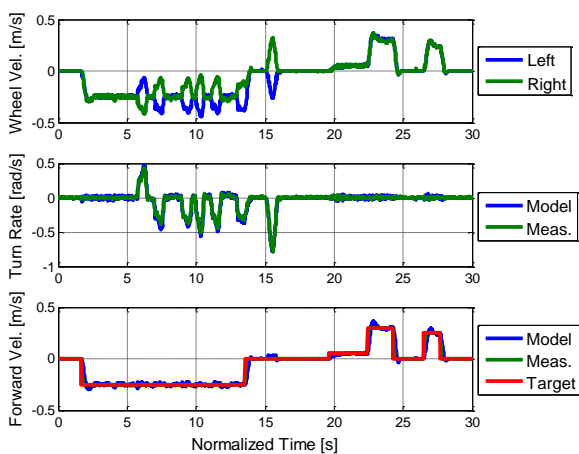

Figure 8. SSMR Model vs. Measured Results

Additional performance improvements were obtained by: incorporating simulated turning maneuvers, increased position accuracy, reduced latencies, control gain scheduling, new higher-performance motors and motor controllers, and high-power wiring. Figure 9 shows a simulation of the obtained control performance enhancements, which have significantly reduced cross-track overshoot and settling time.

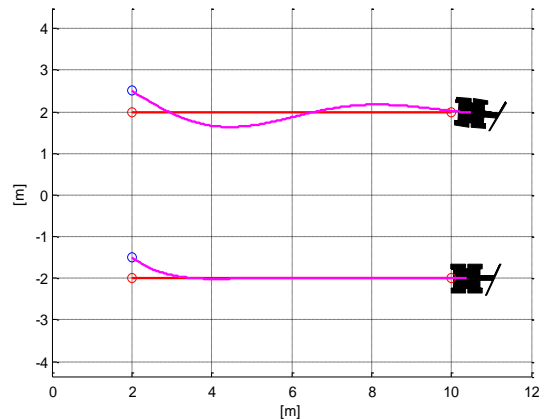

Figure 9. M.A.C.S. Simulated Performance at 1.5 m/s with an Initial Cross-track Error of 0.5 m. Top: M.A.C.S. 2011 (Position-control latency of 0.25 s, Fixed Gain), Bottom: M.A.C.S. 2012 (Latency of 0.1 sec, Gain Scheduling)

The position loop is limited to an update rate of 5 Hz. Since M.A.C.S. reaches speeds up to 1.5 m/s during the competition; the laser will have moved 30 cm during a scan. This causes significant distortion of the laser scan and a subsequent reduction in positioning accuracy. M.A.C.S. compensates for the displacement and the rotation of the laser, by using its gyro heading and wheel speed measurements, to correct for the associated laser scan distortion. This correction, when paired with software optimizations, reduces position loop latency by approximately 0.15 seconds. Continuous calibration of the gyro bias further optimizes overall performance. Figure 10 shows an example measurement of the M.A.C.S. commanded versus actual heading for the current implementation.

Gain scheduling has been implemented in both the low-level heading loop as well as in the high-level position loop. In the heading loop, the control is now more sensitive to small heading errors, allowing the robot to respond more aggressively to small heading adjustments. In the high-level, the velocity has been made a function of the cross-track error. Changes in the controls now reduce the velocity when needed, and the robot is able to reduce and maintain the cross-track error at the cm-level.

Finally, all four motors and encoders have been upgraded to allow for better velocity control. The RoboteQ motor

controllers were replaced by a newer model which enables tighter and higher resolution control and continuous wheel speed readout.

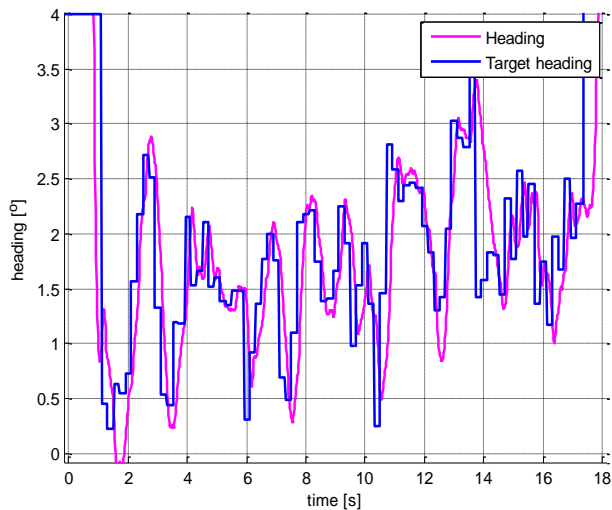

Figure 10. M.A.C.S. Heading Tracking Performance While Plowing in a Straight Line at 1 m/s, Maintaining a Cross-track Error of Less than 2.5-cm.

## PROCESSOR AND SOFTWARE DESIGN

As detailed in the System Design section, M.A.C.S. uses a Quad-Core AMD processor. The processor runs both the high-level and low-level software. The high-level software is written in Matlab® for rapid prototyping and enhanced debugging support. High-level functions include laser processing, path execution, and data storage. The low-level software is written in C++ for speed and low latency. Low-level functions include heading/velocity controller software and drivers for interfacing with sensors onboard M.A.C.S.

Once M.A.C.S. collects data during a test run, all data can be played back both in real-time and fast-time modes for analysis. This methodology is also used after software changes to ensure that the navigation solution continues to function as intended.

## SYSTEM INTEGRATION

The M.A.C.S. snowplow design life-cycle has followed the standard “V” life cycle process. Based on the vehicle design constraints, top-level system requirements, and high-level vehicle performance requirements, an architecture of multiple sub-systems (see Figure 3) was designed (i.e. vehicle sub-system, planning and operation sub-system, navigation sub-system, control sub-system, etc.). Further design detail was added by identifying the sub-system hardware and software components and the interaction between these components (i.e. batteries, motors, plow, planning software, navigation software).

As is characteristic for a “V” life cycle process, the hardware and software components were tested individually to verify that they satisfied the required performance and functional requirements. Next, the sub-system components were integrated and each sub-system tested (i.e. the motor control sub-system was built and tested in the lab, the navigation system was built and tested in an outdoor environment including the beacons, the power subsystems were built and tested in a laboratory and outdoor environment under various loads). After completion of most (or all) of the sub-systems, the sub-systems were integrated and integration testing performed. The emphasis during integration-testing was on the appropriate and safe interaction of the many sub-systems. An example of an integration test was the use of the navigation sub-system by the planning, guidance and control sub-systems for straight motion operation. At all times during these verification activities, problems were identified and appropriate design changes and improvements at the component, sub-system or interface levels were made. Finally, the integrated system was tested extensively in an actual operational environment and its function validated.

## SAFETY SYSTEM

Extensive safety features are built into M.A.C.S. due to its potential to pose a threat to safety with its 5-hp propulsion and 526-lbs weight. An emergency stop systems (ESS) is implemented using high-power relays capable of switching the motor current up to a combined 400 A.

Power to the four motors is enabled if and only if all of the following six requirements are valid:

- 1) Remote stop control is active and within range
- 2) Two physical emergency stop buttons are enabled (pulled-out)
- 3) Motor controllers receive commands at least once per second (watchdog timer #1): fail-safe for processor failure and low-level software bugs
- 4) High-level software passes data to low-level software at least once per second (watchdog timer #2): fail-safe for high-level software bugs
- 5) Guidance calculations determine that snowplow is within the boundaries: fail-safe for guidance and control errors
- 6) At least three beacons are visible to the laser to provide an over determined solution that passes an integrity residual check: fail-safe for laser measurement errors and beacon location errors

To eliminate software malfunctions in the safety system, the motor relays are directly controlled by other relays and switches. Furthermore, all wiring is fused to mitigate potential meltdowns and fires due to short circuits. The safety design for one of the motor controllers is illustrated



by the circuit diagram in Figure 11. The battery banks, which supply power to both motor controllers, are wired in parallel to allow for increased current flow and to extend the duration of operation. Also shown in Figure 11 are the charge connections, which allow for the individual charging of each battery.

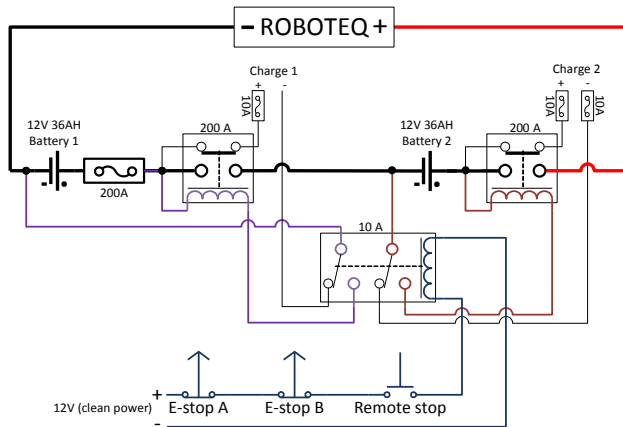

Figure 11. Motor relays and control relays

M.A.C.S. is equipped with two red physical emergency stop buttons, which are located on top of the robot and on the rear status panel. Engaging either button will cause the vehicle to stop, as they both directly control the power relays without the use of an intermediate processor. The safety system is designed to maintain M.A.C.S. within the snow field safety boundaries. This is accomplished by the following:

- Maximum velocity of 1.5 m/s
- A 0.5-m buffer zone maintained between the robot and boundaries at all times
- A stopping distance of less than 0.8 m utilizing the remote stop when traveling at 1.5 m/s
- A stopping distance of less than 1.85 m utilizing the physical emergency stop buttons when traveling at a speed of 1.5 m/s
- A minimal remote stop range of 50 m, with the remote stop being engaged when the transmitter is out of range of the snowplow

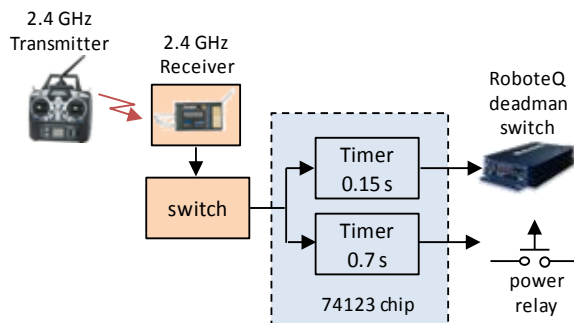

Figure 12. Wireless Remote Power-Off Function

The wireless remote power-off switch is also implemented without the use of a processor and its operation is shown in Figure 12. The throttle command on a wireless 2.4-GHz transmitter is used to activate a solid-state switch that is connected to the throttle receiver channel. When the throttle command is reduced below 66 percent or when the transmitter is out of range of the receiver, the switch triggers two timers. The first activates the RoboteQ's "deadman" switch which initiates active braking, and the second timer deactivates the relays, cutting power, causing the robot to roll to a stop. Testing has verified that both stopping procedures will safely halt movement within competition requirements. For additional information regarding the M.A.C.S. safety system and procedures, see [2].

### FAILURE MODES AND RECOVERY ACTIONS

During the design phase, all failure modes were mitigated. Each of the assessed failure modes and their corresponding recovery actions can be found in Table 3.

Table 3. Failure modes and recovery actions

ID	Failure Mode	Recovery Action
1	Computer system malfunction	Restart the computer. If not successful, replace computer with a spare
2	Motor controller malfunction	Reset motor controller when commanded velocities are not achieved (takes 0.5 s during which time the robot stops)
3	Positioning system malfunction	Stop the snowplow until scanning laser is able to identify at least 3 beacons in 5 successive scans
4	Electrical system failure	Diagnose problem and repair using spare parts
5	Snowplow is obstructed by the simulated post(s)	Stop robot, re-map obstacle location, re-plan and execute updated path plan
6	Snowplow moves one of the beacons	Discard beacon from navigation solution when its residual is larger than a set threshold
7	Stuck	Execute unstuck maneuver

### RISK ASSESSMENT

During the preliminary design review (PDR), eight risk items were identified:

- 1) Traction: Insufficient traction given the use of a larger plow blade and variable snow depth
- 2) Plow: Wide plow design may hinder maneuverability
- 3) Navigation System: Laser beacon system is not accurate enough for velocity increase
- 4) Control system: Controls not sufficiently accurate and/or stable for high speed vehicle dynamics
- 5) Simulated post: Posts may block one or two navigation beacons
- 6) RoboteQ motor controllers: Failure of motor controller

- 7) Encoders: Loss of one or two out of the four encoder feedbacks
- 8) Emergency stop: Given high plowing speed, stopping distance may exceed that allowed by field dimensions and competition safety requirements

All of these risks were addressed during previous competitions and testing at Ohio University with the exception of risk item 5. To mitigate the risk of the two simulated posts, a new initialization algorithm was designed and tested. Tests were also performed in which M.A.C.S. made contact with a simulated post to ensure that no damage or vehicle boundary infractions would result from a possible collision. All risk items were extensively tested with the help of Ohio University's Bird Arena director Dan Morris and his staff. They used the ice resurfacer, on several occasions, to create snow for competition-like testing conditions with variable snow loading and depth, as illustrated in Figure 13.



Figure 13. Test Run using Snow from Ohio University's Bird Arena

## COMMERCIALIZATION AND IMPLEMENTATION

A commercialized version of M.A.C.S. would be intended for small businesses, universities, or cities needing assistance in the clearing of parking lots, sidewalks, loading docks, or bicycle paths. M.A.C.S.'s compact design, of less than 2 m<sup>3</sup>, is excellent for plowing spaces in which a larger plowing vehicle would be unable to maneuver.

Initially, the user would remotely control the robot to make one pass along the perimeter of the area to be cleared of snow, while storing a map of the perimeter and enclosed areas into memory. M.A.C.S. would plow the area, as specified by the previously stored map, utilizing several innovative design features to achieve autonomous operations for snow removal:

- Fully functional in GPS-challenged environments through the use of scanning laser-based positioning utilizing features of opportunity (light posts, fences, trees, walls, etc.)
- LIDAR navigation during snowfall without loss of position accuracy
- IR camera allows detection of encroaching obstacles or people for enhanced safety
- Simultaneous Localization and Mapping (SLAM) utilized to create a map of plowing area then committed to memory for subsequent operations
- Hybrid design power system implementing a gasoline generator for prolonged usage
- Parking station utilizing plug-and-play charging of individual batteries with error-proof connections
- Compact vehicle design allows for maneuvering in tight or crowded areas, on sidewalks, and bicycle paths
- Robust traction provided by a combination of V-profile snow tires, weight, four-wheel drive, acceleration control, and optimal plow width

While prototyping costs of this type of vehicle are approximated at \$22,000, production cost is estimated to be a factor of three improvement upon this at \$7,000. To incur a profit, the commercialized version of M.A.C.S. would likely sell for \$10,000.

## SUMMARY AND PRACTICAL APPLICATIONS

M.A.C.S. has been designed to remove snow in dense urban environments (e.g., sidewalks, parking lots, and cross walks) that are likely GNSS-challenged due to building blockage, severe multipath and/or interference. An eye-safe scanning laser has been selected to provide a reliable navigation solution in this type of environment. The laser also provides obstacle detection and avoidance information which is highly desirable for an autonomous robot. While PVC pipes are used as passive beacons for laser feature extraction to create a robust position solution for the competition environment, practical implementations could also utilize existing features of opportunity (e.g., light posts, fences, trees, and walls). Only three features with good geometry relative to the laser scanner are needed for a redundant navigation solution. With its 250-m laser range and cm-level navigation accuracy, the M.A.C.S. platform will be able to operate in most, if not all urban environments. Some of the other potential applications being explored include snow-plowing on airport runways and unmanned Zambonis for ice rinks.

Another practical application of the M.A.C.S. platform is educational use for research into challenging guidance, navigation and control problems. The Matlab<sup>®</sup> development environment in combination with flexible

TCP/IP and USB interfacing enables rapid prototyping and testing of new robotic concepts.

During the past two years, M.A.C.S. has also been used for outreach programs, including “Young Scholars Ohio,” where a group of young gifted students from several states across the country participated in a workshop to program M.A.C.S. to clear simulated moon rocks from a spacecraft landing site.

## COMPETITION RESULTS

M.A.C.S. autonomously cleared snow from both the “I”-shaped and double “I”-shaped competition paths. Using a multi-pass plowing strategy, with an additional “clean-up” pass and sufficient plow overlap, Ohio University was able to completely clear each competition field and earn the maximum amount of points for each competition run. Team M.A.C.S. also earned an additional 2.13 bonus points and 3.48 bonus points, respectively, for speed of course completion. In addition, Ohio University received a score of 14.36 out of a possible 15 points and a score of 8.41 out of a possible 10 points for the competition’s presentation and technical paper components, respectfully. Team M.A.C.S. earned a total of 103.11 points out of a possible 107.5, including bonus points, winning the competition.

## ACKNOWLEDGMENTS

The M.A.C.S. Team gratefully acknowledges the following sponsors: Ohio University’s Avionics Engineering Center for components, parts and student support, the School of Electrical Engineering and Computer Science for travel support, The Russ College of Engineering and Technology for travel support, The Institute of Navigation and the ION Satellite Division for competition sponsorship, the ION North Star Section for competition operation, management, and constructive feedback on the snowplow design, Xsens Technologies, B.V. for a MTi Inertial Measurement Unit (IMU), Honeywell, Inc. for providing funds for the SICK LD-OEM1000 laser scanner purchase, The Consortium of Ohio Universities on Navigation and Timekeeping (COUNT) for components, parts and student support. The M.A.C.S. team would also like to thank Bird Arena director Dan Morris for the use of the ice rink and for providing test conditions with snow to mitigate our major risk items.

## REFERENCES

[1] The Third Annual Autonomous Snowplow Competition Rulebook, Revision 2013.1.0, available from: <http://www.autosnowplow.com/rulebooks.html> (last accessed on 17 January 2013).

- [2] Craig, S., Kollar, R., Li, K., Duan, P., Pelgrum, W., Van Graas, F., Uijt de Haag, M., “Laser-Guided Autonomous Snowplow Design,” Proceedings of the 25th International Technical Meeting of The Satellite Division of the Institute of Navigation (ION GNSS 2012), Nashville, TN, September 2012.
- [3] Craig, S. Miltner, M., Fulk, D., Pelgrum, W., Van Graas, F., “Monocular Autonomously-Controlled Snowplow,” Proceedings of the 24th International Technical Meeting of The Satellite Division of the Institute of Navigation (ION GNSS 2011), Portland, OR, September 2011, pp. 2127-.
- [4] Minneapolis – St. Paul average temperatures from: <http://www.climate-zone.com/climate/united-states/minnesota/minneapolis-stpaul/> (accessed on 17 January 2013).
- [5] Kozłowski, K. R., Pazderski, D. A., “Modeling and Control of a 4-wheel Skid-Steering Mobile Robot,” International Journal of Applied Mathematics and Computer Science (AMCS), 14(4), 2004, pp. 477–496.

**APPENDIX A.**

Snowplow vehicle design constraints, system requirements, and performance requirements are provided in Tables 4, 5, and 6, respectively. The tables indicate traceability between the various constraints and requirements in the right-most column.

*Table 4. Snowplow Vehicle Design Constraints*

No.	Vehicle Design Constraints (VDC)	Traceability
VDC1	The snowplow shall be autonomous and unmanned and shall not be remotely controlled during the competition.	SR1.1
VDC2	The snowplow shall observe a speed limit of 2 m/s.	SR1.4
VDC3	The system shall be equipped with both a physical power-off switch and a wireless remote power-off switch. The snowplow shall cease operation within 2 seconds of power-off. The snowplow shall be equipped with an electrical ground.	SR2.1
VDC4	The snowplow and any of its attachments shall not exceed 2 m in any dimension.	SR1.5
VDC5	The snowplow tires shall not be augmented with rivets, spikes, or chains and plowing action shall be accomplished through direct contact with the ground surface	SR1.5
VDC6	The snowplow shall be self-powered and contain no power source external to the vehicle. Power shall either be combustible fuel, batteries, or both.	SR1.1
VDC7	Possible points per run will be calculated using the equation defined in §3.4.3 of [1].	SR1.1
VDC8	Two fixed posts approximately 1.5 m high by 0.2 m wide will be placed within the Maneuvering & Plowed Snow Zones during each of the snowfield runs.	SR1.2
VDC9	Competition specific design requirements: 1)The snowplow will complete each course in under 20 minutes (including set up time); 2) The snowplow must stay within the buffer zones; 3) The snowplow shall operate in any weather condition (except for severe weather); 4) Navigation aiding sources must be self-powered; 5) The snowplow must operate with snow depths of approx. 5 -10 cm; 6) The snowplow must completely clear all the snow from the snowfield paths; 7) The snowplow must start and finish within the Vehicle Starting Zone (Garage) on the snowfield.	SR1.1, SR1.2, SR1.3, SR2.2

*Table 5. Snowplow Vehicle System Requirements*

No.	System Requirements (SR)	Traceability
<b>SR1</b>	<b><i>System Functional and Operational Requirements</i></b>	
SR1.1	The system shall be able to execute a user-defined trajectory and plow the snow on that trajectory both autonomously and unmanned while meeting the competition specific design and operational constraints stated in VDC9. ( <b>planning and operation</b> )	VDC1, VDC6, VDC7, VDC9, PR6, PR9
SR1.2	The snowplow shall be able to detect obstacles in the environment as specified in VDC8 and perform a safe obstacle avoidance maneuver that does not violate the operational constraints stated in VDC9. ( <b>collision avoidance</b> )	VDC8, VDC9

SR1.3	The system shall be able to compute a navigation and heading solution in dense urban environments under the severe weather conditions defined in VDC9 with a required navigation and heading accuracy performance following performance requirements PR1 and PR2. ( <b>navigation</b> )	SR1.1, VDC9, PR1, PR2
SR1.4	The system shall have a weight and control system that is capable of performing trajectory-following, plowing and obstacle avoidance in the operational environment defined in VDC9 while keeping the trajectory following error within the control accuracy defined in performance requirement PR1, the speed below the maximum speed defined in PR3, and the turn radius below the maximum turn radius as defined in PR7.( <b>control</b> )	SR1.1, SR1.2, VDC2, PR1, PR3, PR7, PR9, PR11
SR1.5	The system dimensions shall not exceed the dimensions specified in VDC4, PR10 and shall be equipped with tires and a plow that satisfy the constraints defined in VDC5. ( <b>vehicle design</b> )	VDC4,VDC 5, PR10
SR1.6	The system shall have a remote monitoring and diagnostics function for use during operation. ( <b>monitor</b> )	Derived
SR1.7	The system shall have a tele-operation capability to support non-competition operation. ( <b>remote control</b> )	Derived
SR1.8	The system shall have sufficient power to perform the any functions during unloading, testing, and competition as defined in PR8. ( <b>power</b> )	Derived, PR8
<b>SR2</b>	<b>System Safety Requirements</b>	
SR2.1	The system shall have three independent mechanisms to perform an emergency stop, ES (remote hardware ES mechanism, onboard hardware ES mechanism, and onboard software ES mechanism) within the safety response time specified in performance requirement PR5 and constraint VDC3. ( <b>fault tolerance</b> )	VDC3, PR5
SR2.2	Upon a safety stop the system shall stay within the operational environment defined in VDC9 and [1]. ( <b>safety buffer</b> )	VDC9, PR4

Table 6. Snowplow Vehicle Performance Requirements

No.	Performance Requirement (PR)	Value	Comments	Traceability
PR1	Total System Error	0.05 m (rms)	control accuracy of 0.035 m, laser positioning system accuracy of 0.035 m	SR1.3, SR1.4
PR2	Heading Accuracy	10 mrad (rms)	limits position error to 1 cm after 1 m of travel, which is detected/corrected by positioning sensor	SR1.3
PR3	Snowplow Speed	Up to 2 m/s	competition speed limit is 2 m/s	SR1.4
PR4	Safety Stopping Distance	< 3 m	to remain within outer boundaries	SR2.2
PR5	Safety Response Time	< 1 s	at 2 m/s, vehicle will travel at most 2 m	SR2.1
PR6	Blade Angle (1.10-m width)	26 deg.	cover multiple bricks to avoid catching brick edges. This was tested and validated during previous competition	SR1.1

PR7	Vehicle Turn Radius	< 1 m	to stay within the maneuvering/finish/start zones during maneuvers	SR1.4
PR8	Snowplow Power Endurance	30 min	Includes unloading, testing, and competition 'double-I'-shape duration	SR1.8
PR9	Environmental Conditions	-30° to 60° F Snow < 2 in/hr	expected temperature range in St. Paul during the competition (average temperature is 16° F)	SR1.1, SR1.4
PR10	Dimensions	< 2 m	in all dimensions with plow attached	SR1.5
PR11	Vehicle weight	> 500 lbs	derived from extensive testing to ensure traction while plowing 5-10 cm of snow with "soft" tires	SR1.4